

**HOLLOW WALL ANCHOR**

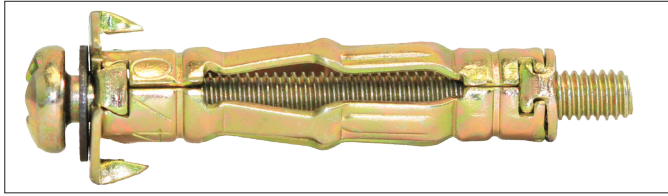

**26.11 PRODUCT DATA**

Head Type:

- Pan
- Phillips Drive

Material Coating:

- Yellow Zinc Plated (Pictured)

**26.12 PRODUCT DESCRIPTION**

The Macsim Hollow Wall Anchor is a four/ five arm metal cavity wall anchor, which gives maximum possible strength by unfolding and keying on to large area behind plaster or wall board. Choose the correct size to suit the wall thickness and diameter of the screw required. The strength is largely dependant on the wall board.

**26.14 APPLICATIONS**

- Hollow Wall Applications
- Wall Board

**26.13 INSTALLATION METHOD**

1. Drill correct diameter hole in plaster or wall board.
2. Insert the assembled screw and body until lugs underside of head engage. Either apply the special expansion tool or carefully tighten screw until the body has fully expanded, ensuring the body does not rotate. In weaker substrates the tool will be required.

**26.15 ADVANTAGES**

- Maximum Strength (depending on wall board)
- Unfolding feature

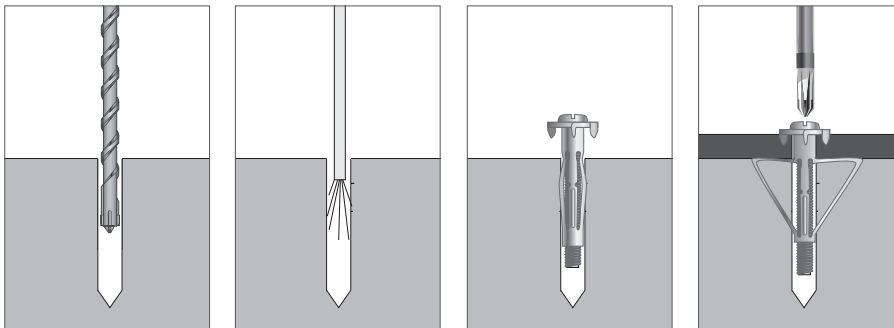

Code	Screw Size	Hole Diameter (mm)	Thickness (mm)	Min. Cavity Depth (mm)	Length (mm)
09405	M4	8	1-5	30	40
09409	M4	8	5-10	30	45
09415	M4	8	3-20	45	55
09416	M4	8	10-16	45	50
09423	M4	8	16-23	50	60
09438	M4	8	23-38	60	75
09510	M5	11	5-10	35	45
09516	M5	11	10-16	45	50
09527	M5	11	16-32	50	75
09616	M6	13	10-16	35	45
09627	M6	13	16-32	60	75
09410*	M4	6.5	3-10	30	40

\* Crown Anchor

**HOLLOW WALL ANCHOR**

**26.16 MATERIAL SPECIFICATIONS**

CODE	Size	Screw Head	Body Specification	Screw
094/5/6	All	Machine ph	Steel YZP	Steel ZP. Pass
09410	M4 x 6.5	Machine ph	Aluminium	Aluminium

**26.17 TECHNICAL SPECIFICATIONS**

CODE	Size	Advisory SWL Tension Plasterboard 10mm N	Advisory SWL Tension Plasterboard 13mm N	Advisory SWL Tension Plywood 10mm N	Advisory SWL Shear N
094**	4mm	100	150	300	n/a
095**	5mm	100	200	400	n/a
096**	6mm	150	220	500	n/a
09410	4mm	100	n/a	200	n/a